

AIR PREPARATION UNITS

FILTER REGULATOR COMBINATION series

Kushako

Filter Regulator Combination details :

Features :

- Modular type for easy and fast maintenance.
- Suitable for wall mounting.
- Filter
 - Bronze / Plastic sintered element
 - Separator and shield for efficient moisture separation.
 - Press type Manual drain for easy operation .
- Regulator
 - Diaphragm operated, relieving type .
 - Pressure compensated by balanced poppet .
 - Non raising 'Press to lock' adjusting knob for locking at any set pressure.

Precautions :

- Note the direction of flow before installation & connect pipe accordingly.
- Nipples of taper threads to be used with teflon tape. Ensure teflon tape does not enter the unit during tightening.
- Flush piping for dirt, dust, rust & other foreign particles.
- Install in clean atmosphere.

Technical Specifications:

Model	FRC-2016-STD
Medium	Compressed air
Port Size	G1/4 , 3/8 , 1/2 BSP / NPT (F)
Pressure gauge port size	G1/4 / 1/8 , BSP / NPT (F)
Flow rate (Ltr / Min)	3000
Maximum supply pr. (bar)	12
Regulating pr. range (bar)	0 - 2, 0 - 4, 0 - 7, 0 - 10 (Standard)
Ambient / Medium temp.	-5° to 60° C
Filtration (μm)	1, 5, 25 & 40 (standard), 50 , 100
Bowl capacity (ml)	50
Recommended oil	ISO VG 32
Bowl material	Polycarbonate
Installation	Vertical
Materials of construction	Aluminium, Brass, SS, Nitrile
Optional accessories	Clamp, Modular mounting kit, Pr gauge
Weight (Kg)	1.0

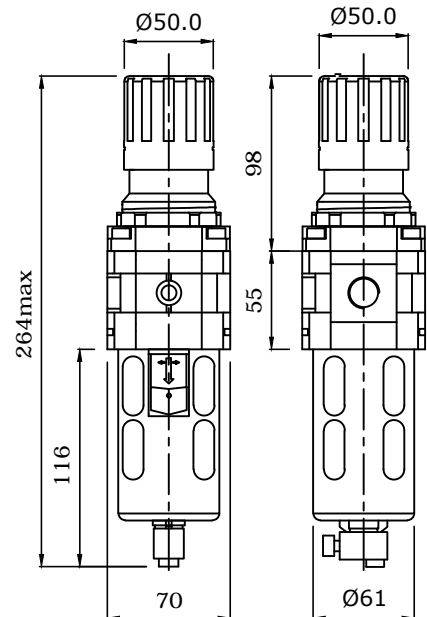

Bracket



Pr. Gauge

Kushako

Manufactured by :

Kushako India

Office : 490, Narayan Peth, Opp. Pune Marathi Granthalaya, Pune - 411030. (Maharashtra). Website : www.kushakoindia.com

Works : Sr.No. 25/1A, Village Nanded, Sinhgad Road, Tal - Haveli, Dist. Pune - 411041

Tel. No : 901169077 / 7620674777

E-mail : kushako.india@gmail.com / kushakoindia1992@gmail.com